

INSTALLATION GUIDE

SOLID HARDWOOD FLOORING

The investment that flooring represents in the home is an important one and customers want their flooring to last. In light of this fact, the importance of product quality and the quality of flooring installation is quite obvious.

Following the instructions in this installation guide will lead to your total satisfaction with Floor & Decor solid hardwood flooring for years to come. These installation guidelines provide minimal requirements. However, the installer must ensure compliance with legislation in effect in the country where the products are installed.

The installation of flooring should be the last step in the construction or renovation of a house.

CAREFULLY READ INSTRUCTIONS AND INFORMATION ON THE FLOOR AND DECOR WARRANTY BEFORE PREPARING AND INSTALLING YOUR FLOORING.

PREPARATION

The environment

- In order to obtain the best possible installation, the installer must ensure that environmental conditions on the premises are ideally suited to the installation of hardwood flooring.
- The house must be heated to a constant temperature of 22°C (72°F) for one week beforehand in order to stabilize both temperature and relative humidity levels on the premises.
- A few days before the installation, relative humidity on the premises must be stable at 37% to 45%.
- At the time of installation, the ambient temperature should read ideally 22°C (72°F).

Boards must be stored on the premises 48 hours prior to installation in order to allow the wood to acclimatize to ambient conditions.

Material and Tools

- Moisture indicators for ambient air and wood
- Miter saw
- Handsaw
- Air compressor and pneumatic floor nailer for hardwood flooring (proper use)
- Measuring tape
- Finishing air-hammer
- 1 1/2 in (38 mm) flooring nails or staples
- Hand drill and 3/32 in (2 mm) bits
- Crowbar
- Hammer
- Nail punch
- Tapered 2 in (5 cm) finishing nails
- Pullbar and block
- Chalk line
- Putty knife
- Wood glue
- Table saw
- Electric drill
- Vapour barrier paper (asphalt-free)

- Square sliding-t-bevel square
- Broom or vacuum cleaner
- Repair and maintenance kit

Regular tool maintenance ensures quality installation.

Check the floor nailer seating plate before beginning your work, and often during the installation, in order to avoid scratching flooring boards. During the installation, wear protective gear to avoid possible injuries.

SUBFLOOR PREPARATION

Once the old floor covering has been removed, the subfloor must be carefully inspected in preparation for flooring installation.

Subflooring and Joists

Before installing your hardwood floor, it is crucial to ensure that you have an appropriate subfloor (veneers or oriented strand boards). The thickness and choice of material for the subfloor will depend on the width between the joists. Using particle boards is not recommended.

If the distance between joists is 12 in (30.5 cm) or 16 in (40.6 cm):

- Use a veneer no less than 5/8 in (16 mm) thick
- Use oriented strand boards not less than 3/4 in (19 mm) thick

Using a CDX veneer of 5/8 in (16 mm) is only possible when the distance between the joists is 16 in.

If the distance between joists is 19 in (48.3 cm):

- Use a veneer of not less than 3/4 in (19 mm) thick
- Use oriented strand boards not less than 3/4 in (19 mm) thick

At the time of installation, the subfloor humidity level must not exceed 12%.

Inspect the subfloor completely. Cracks and flaws are weak points in the subfloor and must be corrected.

Subfloor preparation consists essentially of:

- removing any remaining glue or staples and completely driving remaining nails from the old floor covering into the subfloor;
- evening out the subfloor area by sanding uneven spots.

When necessary, ensure that the boards are solidly fastened to joists. Install screws every 8 in (20 cm). Screw shanks should not be threaded up to their head.

Once inspected, and after corrections have been made, the subfloor should show no differences in level. Remember that a hardwood floor will not correct major or apparent defects in a subfloor. Therefore, it is vital that the subfloor be inspected prior to installing the hardwood.

INSTALLATION OF VAPOUR BARRIER PAPER (ASPHALT-FREE)

If a floor is glued and nailed down, it is not necessary to use an unsealed vapor barrier.

The installation of vapour barrier paper is highly recommended.

The paper insulates the subfloor, preventing humidity from coming into contact with the hardwood flooring. The vapour barrier (asphalt-free) paper must be laid parallel to flooring boards with edges overlapped 2 to 3 in (5 to 8 cm).

INSTALLATION GUIDE

SOLID HARDWOOD FLOORING

INSTALLATION OF FLOORING ON A CONCRETE SUBFLOOR

Due to major fluctuations in humidity levels, hardwood flooring installed in basements or at ground level should be laid as follows:

First method:

- Use a hygrometer to check the moisture content in the concrete. It should not exceed 5%.
- Glue or nail in place sleepers spaced 12 in (30 cm) centre-to-centre and overlap ends at least 4 in (10 cm).
- Lay down a layer of polyethylene overlapping edges 2 to 3 in (5 to 8 cm).
- Install boards securing them to joists.

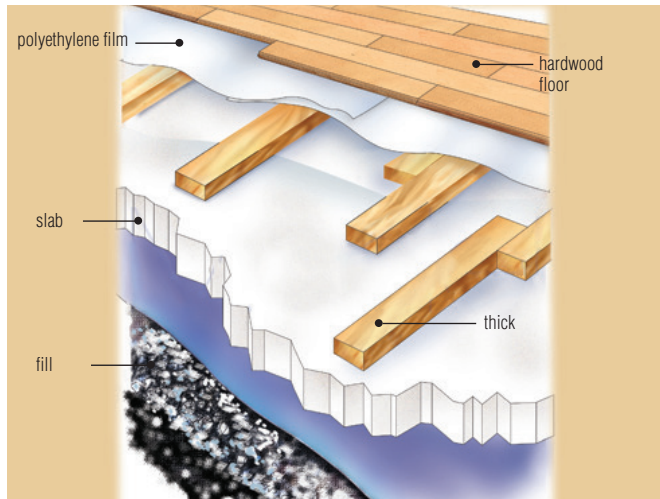

Second Method:

- Use a hygrometer to check the moisture content in the concrete. It should not exceed 5%.
- Glue or nail in place joists around the room perimeter and over the entire floor surface spaced 16 in (40 cm) centre-to-centre in the opposite direction from how flooring boards are to be installed.
- Lay down a layer of polyethylene overlapping edges 2 to 3 in (5 to 8 cm).
- Install plywood sheets with tongue-and-groove fit over the joists.
- Lay down tar-free vapour barrier paper over the plywood.
- Install boards normally.

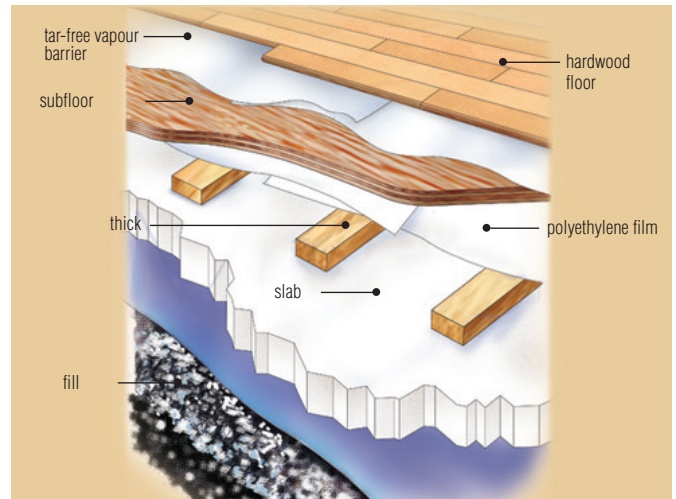

BEGINNING WORK

Before beginning work, ensure that the premises benefit from sufficient natural lighting.

Parallelism and Squareness

When flooring is to be laid in a house, the entire house must be checked for wall parallelism and squareness in order to determine if any walls may not be parallel and to plan installation in consequence thereof.

By using exterior walls as benchmarks, measuring squareness will precisely verify the parallelism of each interior wall and any obstacles (such as ceramic floors, stairwells, fireplaces, etc.). Thus, the installer will avoid relying on work carried out improperly beforehand.

Installation Benchmarks

Squareness can be instrumental in selecting one wall over another as the departure point. Normally, the most prominent wall in the room should be selected unless, of course, a ceramic floor joint proves to be a more interesting departure point.

When flooring is to be laid throughout a house, one should normally begin in the longest room, generally the hallway.

Board Selection

Board selection allows the installer to lay out a sample representative of the final result. This is the time when wood shades and board lengths can be mixed and matched to offer an opportunity to visualize the future flooring.

Note that a 5% industry standard set for imperfections in boards does not include waste from the installation itself.

The installer must examine each board before laying it down. Any board installed (nailed in place) shall be considered accepted by the installer and/or owner. Such boards may not be claimed under warranty on the basis of manufacturing defects or classification errors.

Installing the First Row

Remove baseboards and finishing trim with a putty knife. Once the flooring is laid, replace baseboards and finishing trim, nailing them to walls and not to the flooring.

Trim the moulding around doors in order to be able to insert boards. Pay attention to finish details.

Before beginning work, ensure that joists are perpendicular to the first boards laid.

When laying down the first rows of boards, choose the straightest boards in the entire lot.

INSTALLATION GUIDE

SOLID HARDWOOD FLOORING

Expansion Space

The expansion space all around the room plays a fundamental role in ensuring the durability of flooring, allowing the wood to expand and contract with variations in relative humidity in the room.

When humidity levels in a room vary dramatically, the accumulated expansion and contraction of the flooring may result in damage to the appearance or durability of the flooring.

The established standards are 3/4 in (1.9 cm) for the width of the board, 1/4 in (0.6 cm) for the length.

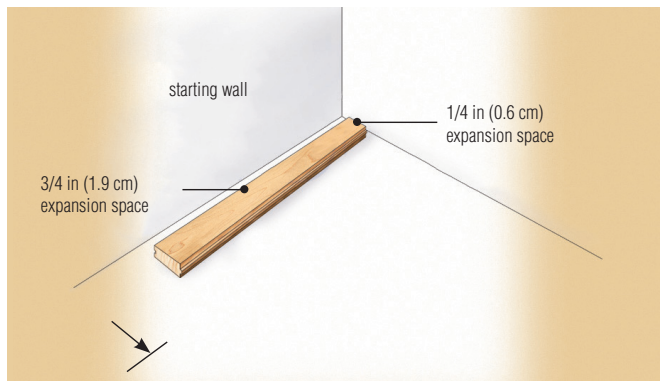

- If there are baseboards and finishing trim, conform to installation standards for expansion spaces.
- If there are baseboards only and their width is insufficient to cover the expansion space, cut a strip of gypsum at the bottom of the wall where an expansion space is required.

When using the chalk line to draw the line for the first row of boards, it is important to include the 3/4 in (1.9 cm) expansion space when calculating the board width.

ASSEMBLING THE FIRST ROWS OF BOARDS

A line must be drawn for the first row to indicate positioning.

There are two methods of installing the first row of boards.

First method (with face nail):

This method consists of hammering a nail into the top of the board 1 in (2.5 cm) from the side of the wall. Ensure that the nail is well hammered in and hide it with a crayon provided in our repair kit.

Second method (without face nail):

This method is used when one does not want boards nailed down as in the first method. Glue is applied to the underside of the board at 6 in (15 cm) intervals. The type of glue used should respect wood expansion properties. Do not use woodworking glue. This method ensures board stability without retention over its entire surface, which would hinder any future expansion or contraction.

The first boards of the first row are also held in place by nails driven into the tongue at 45° using the finishing air-hammer.

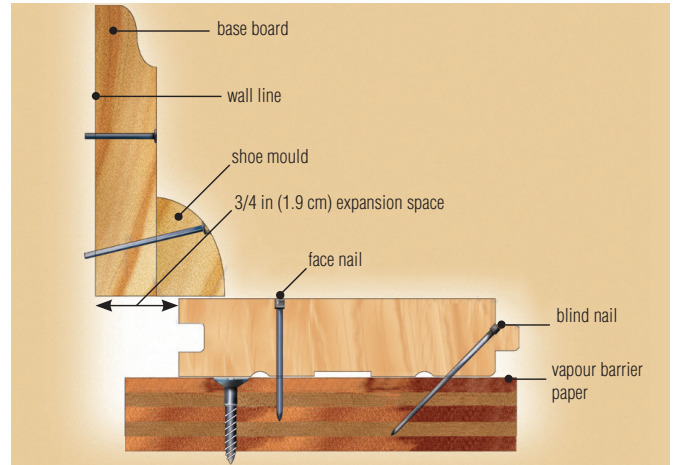

COMPLETING THE FLOOR

Nail in second row of boards using the finishing air-hammer to avoid affecting the alignment of the first row. Subsequent rows of boards must be nailed down in the same fashion, with nails driven in the tongue at 45°, this time using the conventional floor nailer air-hammer.

Each row of boards, including the first row, must be nailed down with a minimum of two nails, ideally spaced at 6 to 8 in (15 to 20 cm) intervals, depending on board length. A combination of glue and nails provides greater stability for boards greater than 5 inches in width. Be sure to choose waterproof glue sold specifically for hardwood. Note also that a nail located less than 2 in (5 cm) from a board end could eventually cause the board to split.

When a board must be cut to complete a row, it is better to start the next row using the remaining piece. Ensure that cut boards measure more than 6 1/2 in (16.5 cm).

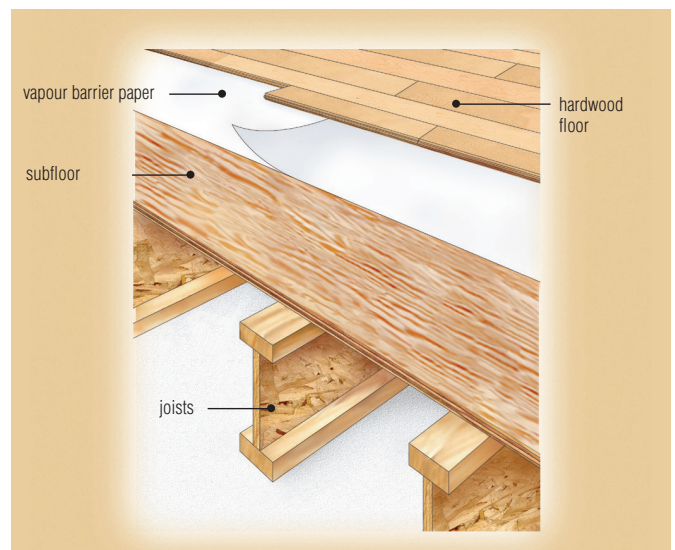

INSTALLATION GUIDE

SOLID HARDWOOD FLOORING

Air-hammer and Rubber Mallet

When laying down a board, it is important to distinguish between adjustment and nailing down.

Adjustments are made solely using the rubber mallet. The mallet serves to move the board slightly, without damaging the wood.

The air-hammer is used only to secure the board in place after adjustment. The force applied with the air-hammer must be measured with this sole aim in mind.

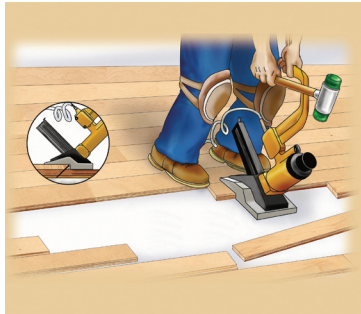

Both the conventional floor nailer and finishing air-hammers must be calibrated according to manufacturer's specifications. To verify compliance with manufacturer's specifications, test the tools on a piece of scrap wood in order to avoid damaging good boards. This method will avoid damage to boards resulting from too much air pressure, too much physical pressure applied to boards or misuse of the air-hammer.

Use of a 7 in (18 cm) floor nailer seating plate will distribute pressure on the wood surface and decrease the risk of damage to boards.

Board ends in each row must be staggered at least 6 in (15 cm) from the previous row. Staggering board ends improves floor aesthetics and stability in the presence of humidity variations. Pressure from boards expanding and contracting acts on the next row of boards, tending to limit and evenly distribute pressure on the entire floor surface.

Periodically verify row parallelism in order to make appropriate adjustments.

FINISHING UP

The Last Rows

When use of the floor nailer is impossible because the last rows (generally the last three) are too close to the wall, finish the job in the following manner.

Select a board and drill 45° holes in the tongue. Once the board is laid, the holes are used to drive in finishing nails using an ordinary hammer. Then use a nail punch to completely embed nail heads.

Since the rubber mallet may not be used in the adjustment of the last rows of boards, use a crowbar instead.

As in the installation of the first rows of boards, there are two methods of installing the final rows.

First method:

This method consists of hammering a nail into the top of the board 1 in (2.5 cm) from the side of the wall. Ensure that the nail is well hammered in and hide it with a crayon provided in our repair kit.

Second method:

This method is used when we do not want boards nailed down as in the first method. Glue is applied to the underside of the board at 6 in (15 cm) intervals and a nail is driven into the tongue at the end of the board at a 45° angle.

Boards in the second row should be secured in place using the finishing air hammer to avoid affecting the alignment of the first row.

Pieces of wood wedged between the last row of boards and the wall may be used to hold the wood in place until the glue has bonded.

SPECIAL CASES

Reverse Installation

Sometimes flooring laid down from one room to another requires that boards be installed in reverse order using a slip tongue. The slip tongue transforms a board groove into a tongue, making it possible to lay a board down in the opposite direction. Holes are drilled in the board groove and the board is secured in place with finishing nails. The slip tongue is then coated with glue and inserted into the board groove, resulting in a tongue. When a new row of boards is laid, installation then proceeds in reverse order.

Walls at 45°

Walls at 45° decrease the amount of support provided to subsequent rows of boards by the first rows. In order to avoid possible misalignment, use a finishing air-hammer or ordinary hammer to nail in finishing nails for added support. Do not forget to avoid hammering in nails within 2 in (5 cm) of board ends.

Abutting Ceramic Surfaces

At junctions with ceramic flooring, we recommend that a board of the same species of wood as the flooring be used to limit ceramic flooring contours.

Nosing

Special boards called nosing can demarcate flooring at a landing. Glued and nailed in vertically, they provide a solid end to flooring.

Reducer Strips

Room level may vary from one room to the next. Reducer strips solve the problem. Glued at 45°, they provide the junction between two heights and compensate for a change in level between rooms

Glued Installation

To benefit from the warranty offered for Floor & Decor products if you select to glue your hardwood flooring in place, you must obtain a letter from the glue manufacturer stating that the manufacturer guarantees the glue to be compatible with Floor & Decor products.

Note: Some boards may curve slightly without being considered defective because they may be straightened out during installation.

INSTALLATION GUIDE

SOLID HARDWOOD FLOORING

INSTALLING HARDWOOD FLOORING BOARDS IN A CONDO

It is possible to install hardwood flooring in a condo as long as the total height of the sub-floor (acoustic felt and plywood) and flooring boards has been anticipated. Soundproofing, which is an important factor in condos, must also conform to the established standards of each group of owners.

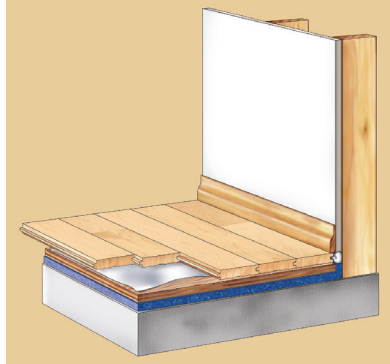

1st Step

Preparing the sub-floor

The first step consists of checking the humidity level in the concrete, which must not exceed 5%. Then lay down a layer of acoustic felt over the entire flooring area. An extra 1/2 in (1.3 cm) of space must be allowed around the entire perimeter of the room and an extra half-inch added to the total thickness of the floor to account for the felt.

2nd Step

Lay down the plywood diagonally opposite the direction in which the flooring boards are to be laid in order to increase flooring strength. The 5/8 in (1.6 cm) plywood tongue-and-groove sheets are simply laid down on the felt but neither screwed nor nailed in place, resulting in what is known as floating flooring. Apply carpenter's glue along 8 in (20 cm) sections of each groove at twelve-inch intervals. Since the plywood is not grooved at either end, use a router and a 1/4 in (0.6 cm) square head bit to install an insert that will maintain the plywood sheets level while the hardwood flooring boards are laid down. Allow for a 3/4 in (1.9 cm) space around the room perimeter. To avoid creaking and grating of the floating floor at entrances and along abutting ceramic floors, install a strip of plywood 3/8 in (1 cm) thick and 2 1/2 in (6 cm) wide at these locations. Use acoustic adhesive to glue a sound impact strip of 1/8 in (0.3 cm) thick under the plywood strip in order to stabilize the floating floor and ensure adequate soundproofing.

3rd Step

Install approved vapour barrier paper on the subfloor.

4th Step

Install the hardwood flooring boards, following this Installation Guide. Note: The nails or staples used must have 1 1/2 in (3.8 cm) of length.

INSTALLING HARDWOOD BOARDS ON A RADIANT HEATING SYSTEM

Successfully installing hardwood flooring over a radiant heating system calls for some special precautions. As you are aware, the higher the temperature, the more the air and the materials in the immediate vicinity tend to dry out. In light of this, consumers hesitate to install wood flooring on a radiant heating system because they fear that the flooring will contract, leading to unsightly cracks between the boards. Precautions can be taken to avoid these problems: among others, avoid installing boards greater than 5 inches (127 mm) in width. Since radiant heating affects ambient temperature more quickly than standard heating systems, the humidity rating in the air must be carefully controlled and

maintained between 37% and 45% all year long. To achieve this, depending of the season, a humidifier or a dehumidifier must be used. If hardwood flooring is to be installed on radiant heating, first ensure that a heat and leak test has been carried out and the system has been turned on and off a number of times over a period of several weeks prior to installation of the flooring. The heating system must be turned off and room temperature must be reached before installing the flooring. Once the installation is completed, gradually increase the heat temperature by 3 °C (5.4 °F) per day until the desired temperature is reached. The surface temperature of radiant heating system must never exceed 28 °C (82.4 °F).

There are four standard methods of installing hardwood flooring boards on a radiant heating system.

The **first method** consists of installing the hardwood flooring boards on a plywood sub-floor covered with vapour barrier paper resistant to above-normal temperatures, 30°C (85°F).

The plywood is screwed into place on the floor joists between which the radiant heating system is installed.

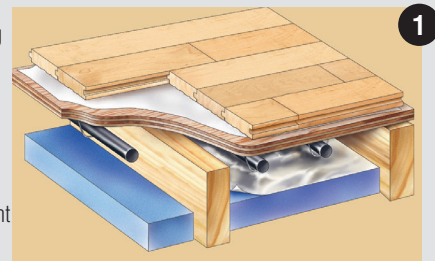

The **second method** is used when hardwood flooring boards are to be installed on an already existing floor, or when it is impossible to install the radiant heating system between the floor joists. This method consists of installing the hardwood flooring boards on a new sub-floor covered with vapour barrier paper and supported by the ledger strips of the old flooring. The radiant heating system is installed between the ledger strips.

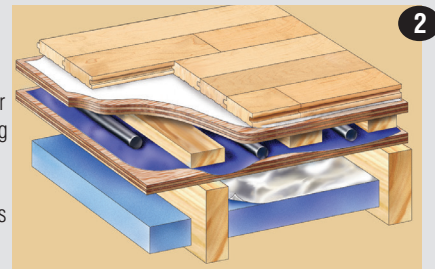

The **third method** is used to create more constant heating. First, a coat of cement is laid between the ledger strips over the radiant heating coils. Then the plywood covered with vapour barrier paper is installed.

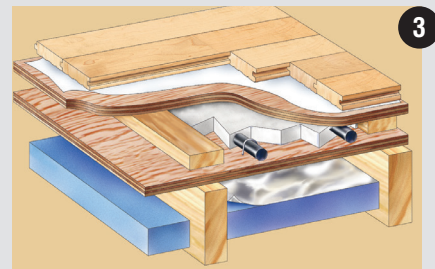

The **fourth method** involves installing the hardwood flooring boards on a radiant heating system installed directly in a concrete slab, either in a sub-floor or a building with concrete floors. A sub-floor consisting of two 1/2 in (1.3 cm) sheets of interlocking plywood covered with vapour barrier paper is then installed directly on the concrete. This type of installation is often referred to as a floating floor.

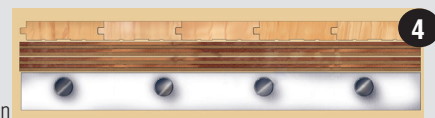

INSTALLATION GUIDE

DO'S AND DON'TS



Air-hammer nailer held at the wrong angle

In this illustration, an air-hammer held at the wrong angle may damage the side of a board, which could lead to small splits appearing along the surface of the side of the board immediately or later.



Piece of plaster left under the subfloor

This illustration shows what happens when a piece of dried plaster remains on a subfloor. The subfloor should be inspected carefully and bits and pieces of dried plaster removed before laying down wood flooring to avoid undue stress on boards that may eventually crack, especially in the middle.



Staples driven in too deeply

This illustration shows a staple driven in too deeply. As a result, cracks may appear on each side of the staple. The cracks may follow the wood grain right up to the surface of the board.

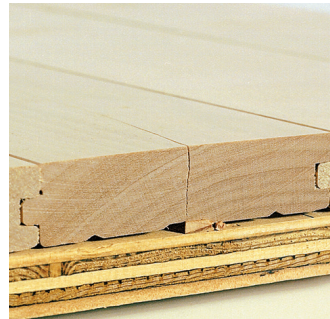

Sliver of wood left between boards and the subfloor

In this illustration a small sliver of wood has been left between the boards and the subfloor. This situation can lead to undue stress on boards that may crack right away, or perhaps later. It is very important to clean the subfloor before laying down wood flooring.

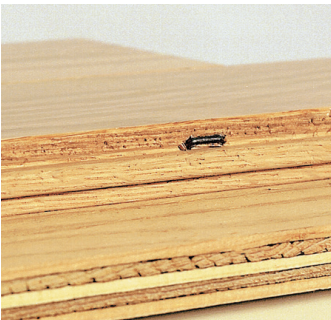

Staples not driven in deeply enough

This illustration shows a staple not driven in deeply enough. This will impede a perfect assembly, which will damage the next board laid down. Moreover, since the boards are not properly secured in place, the floor will creak when walked on and cracks may even appear in one or more of the boards.

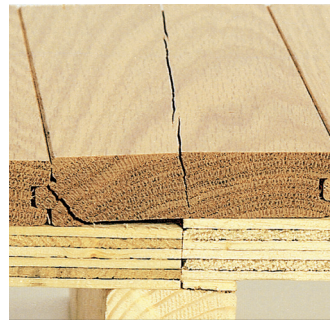

Uneven subfloor

This is an illustration of an uneven subfloor. Boards laid down on an uneven subfloor can cause boards to crack immediately or later.



Using the nailer seating plate on the air-hammer

This illustration shows how the use of a seating plate can help prevent the errors described previously. The seating plate is designed to fit most models of air-hammers, providing the installer with a larger surface with which to press the hammer at a straighter angle against the tongue of the board rather than the side. Using a seating plate prevents damage to the side of a board.



Boards glued down full-length with a water-based adhesive

This shows boards glued down full-length with a water-based adhesive. As you are aware, water and wood are not compatible. The water has caused the wood to swell underneath, and it will remain so even after drying.



REPLACEMENT OF FLOORING BOARDS

FOR THE NAILED OR STAPLED INSTALLATION

Individual wood flooring boards can be repaired/replaced in solid or engineered products without affecting adjoining boards. Always check the species to insure a proper match. Prefinished boards should be selected for gloss and color match.

Removing the plank or strip on wood and concrete subfloors

- Make sure you have a replacement board.
- Set a circular saw to the depth of the thickness of the board to be removed. Make one cut inset 1/2 in (1.3 cm) from groove side running from end to end on the board to be removed.
- Make a second cut inset 1/2 in (1.3 cm) from tongue side running from end to end on the board to be removed.
- Make a third cut across the center of the board at a 30-45° angle from first long cut to second long cut.
- With a chisel cut completely through both ends at cut lines and lift out center of the board. The groove side piece can now be easily removed.
- Carefully remove nails or staples and side tongue piece. Avoid damage to adjoining boards.

Replacing flooring that has been nailed/stapled down

- Clean all debris from the area.
- Measure the opening and cut replacement board to size.
- Carefully test the new board against the opening for precise fit.
- From the back side of the replacement board, cut lower half of its groove side and end match with a table saw so that it will fit over the tongue of the adjoining boards in the replacement area.
- Apply strips of adhesive 6 in (15 cm) apart to the back of the replacement board or to the subfloor.

Use a polyurethane adhesive so the board can expand and contract. Do not use carpenter's glue.

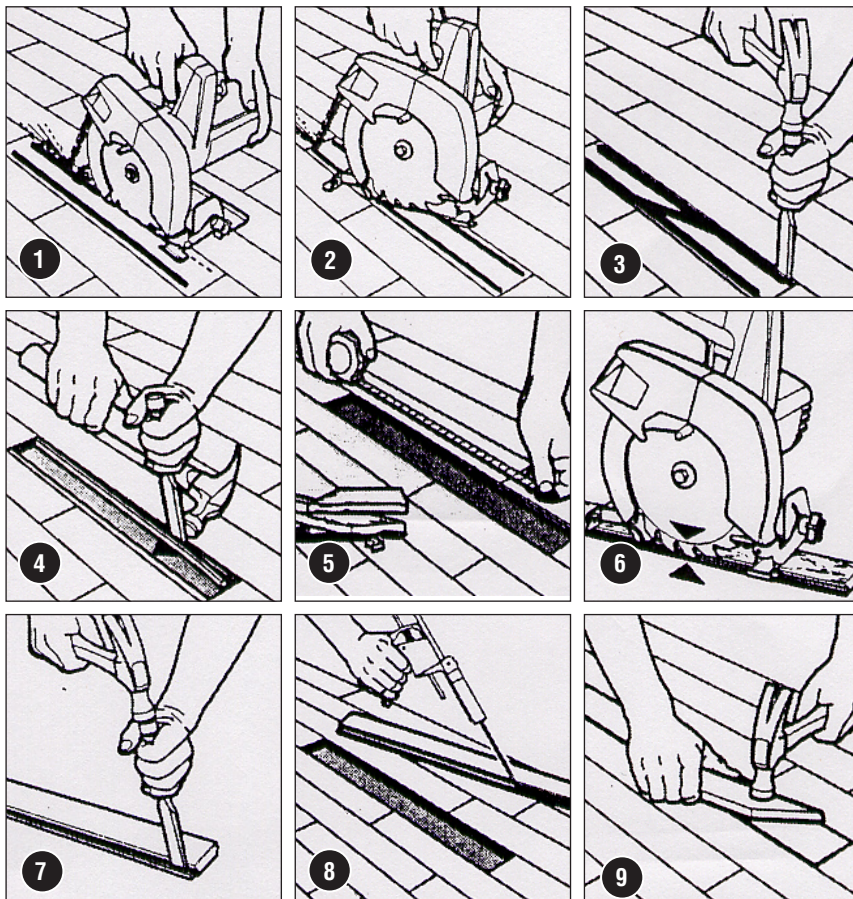

Replacing flooring that has been glued down.

- Clean all debris and old adhesive from the work area. Repair subfloor if necessary.
- Measure the opening and cut replacement board to size.
- Carefully test the new board against the opening for precise fit.
- From the back side of the replacement board, cut lower half of its groove side and end match with a table saw so that it will fit over the tongue of the adjoining boards in the replacement area.
- Apply strips of adhesive 6 in (15 cm) apart to the back of the replacement board or to the subfloor.

Use a polyurethane adhesive so the board can expand and contract. Do not use carpenter's glue.

MAINTENANCE GUIDE

FOR PREFINISHED FLOOR

MAINTENANCE

Instructions for maintaining your Floor & Decor hardwood flooring:

- Before using an hardwood flooring cleaner, vacuum or sweep floor to remove dust and sand.
- Lightly spray cleaner onto a section of floor or spray directly onto mop until damp.
- Mop back and forth lengthwise along flooring boards.
- Always complete one section before moving to another.

To remove tough stains, pour a little cleaner on a damp cloth and rub lightly. Always wipe surfaces dry. To avoid serious damage to flooring, never pour cleaner directly onto varnished surfaces.

REMINDER:

- Never use wax, oil-based soap or other household cleaners to clean flooring. These products can discolour flooring or leave greasy build-up.
- Machine wash the mop cover frequently, just as you would any cotton towel.
- Never wash prefinished flooring with vinegar and water, as vinegar has an oxidizing effect on the finish.

PREVENTIVE MEASURES

- Sweep or vacuum the floor often to eliminate abrasive dust that can scratch flooring.
- Place doormats at entrances to avoid tracking sand and dirt into the house.
- Protect flooring by installing felt runners under furniture or chair legs to avoid scratches when they are moved.
- When moving heavy furniture, lift it to prevent scratching the flooring.
- Place step-on mats in work areas in the kitchen where water or oily detergents may damage the flooring.
- Place waterproof plates under potted plants to prevent accidental spillage. Use flowerpots with a glazed surface rather than porous ceramic which can leak.
- Any spillage should be wiped up immediately before the wood fibres absorb it.
- Try to maintain house humidity levels as constant as possible (between 37% and 45%) by using a humidifier or dehumidifier, as needed.
- Ambient house temperatures should range between a comfortable 18°C and 22°C (65°F and 72°F).

Fading caused by exposure to the sunlight is a natural phenomenon. When possible, avoid exposing flooring to direct sunlight or bright lights.

EQUILIBRIUM MOISTURE CONTENT BASED ON AMBIENT TEMPERATURE AND RELATIVE HUMIDITY

| TEMPERATURE | | RELATIVE HUMIDITY (%) | | | | | | | | | | |
|-------------|----|-----------------------|-----|-----|-----|-----|-----|-----|-----|------|------|------|
| F | °C | 15 | 20 | 25 | 30 | 35 | 40 | 45 | 50 | 55 | 60 | 65 |
| 32 | 0 | 3.8 | 4.7 | 5.6 | 6.4 | 7.2 | 7.9 | 8.7 | 9.5 | 10.3 | 11.2 | 12.2 |
| 41 | 5 | 3.8 | 4.7 | 5.6 | 6.3 | 7.1 | 7.8 | 8.6 | 9.4 | 10.2 | 11.1 | 12.1 |
| 50 | 10 | 3.8 | 4.6 | 5.6 | 6.3 | 7 | 7.8 | 8.5 | 9.3 | 10.1 | 11 | 12 |
| 59 | 15 | 3.7 | 4.6 | 5.5 | 6.2 | 6.9 | 7.7 | 8.4 | 9.2 | 10 | 10.9 | 11.9 |
| 68 | 20 | 3.6 | 4.5 | 5.4 | 6.1 | 6.8 | 7.6 | 8.3 | 9.1 | 9.9 | 10.8 | 11.8 |
| 77 | 25 | 3.5 | 4.4 | 5.2 | 6 | 6.7 | 7.5 | 8.2 | 9 | 9.8 | 10.6 | 11.6 |
| 86 | 30 | 3.5 | 4.3 | 5.1 | 5.9 | 6.6 | 7.3 | 8 | 8.8 | 9.6 | 10.5 | 11.4 |
| 95 | 35 | 3.4 | 4.2 | 5 | 5.7 | 6.4 | 7.1 | 7.9 | 8.6 | 9.4 | 10.3 | 11.2 |
| 104 | 40 | 3.2 | 4 | 4.8 | 5.5 | 6.2 | 6.9 | 7.7 | 8.4 | 9.2 | 10 | 11 |

Target moisture values