

Dimension: 1.77" w x 0.345" h

V-SR-14

WATERPROOF SURFACE REDUCER

Used to fill the gap between two floors of unequal height.

Used with floors ranging from 2-6mm height.

Surface: Wear resistant
Core Material: Rigid PVC

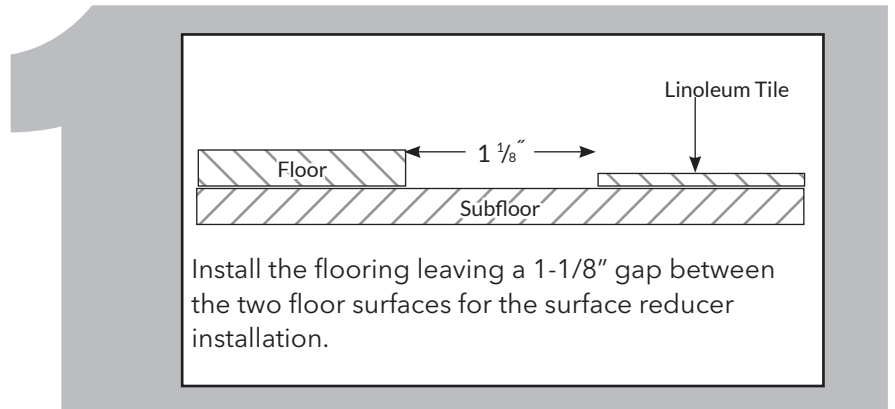

Install the flooring leaving a 1-1/8" gap between the two floor surfaces for the surface reducer installation.

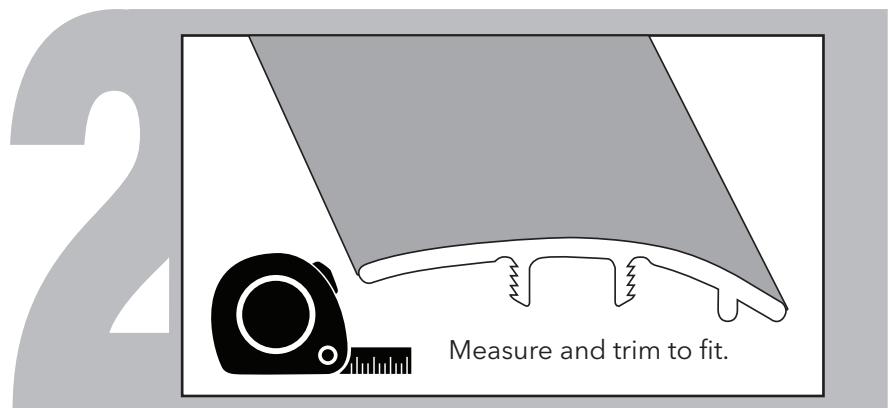

Measure and trim to fit.

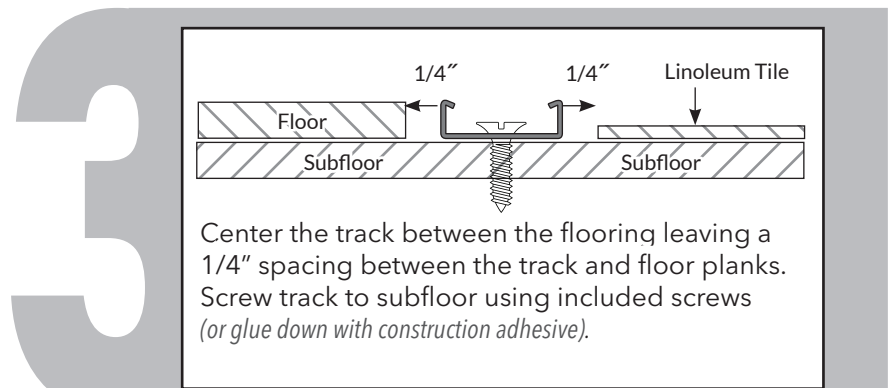

Center the track between the flooring leaving a 1/4" spacing between the track and floor planks. Screw track to subfloor using included screws (or glue down with construction adhesive).

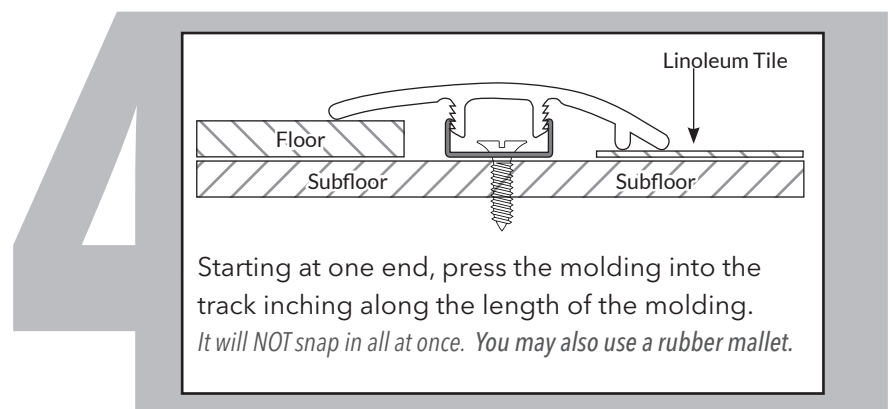

Starting at one end, press the molding into the track inching along the length of the molding. It will NOT snap in all at once. You may also use a rubber mallet.