



# Mapesonic<sup>TM</sup> 2

## Premium Sound-Reduction and Crack-Isolation Sheet Membrane



### DESCRIPTION

*Mapesonic 2* is a patent-pending, next-generation, flexible, 76-mil thin, lightweight, load-bearing, fabric-reinforced "peel-and-stick" sound-reduction and crack-isolation membrane. Application of *Mapesonic 2* can be immediately followed by installation of flooring: ceramic tile or stone with a recommended MAPEI polymer-modified, cement-based mortar; luxury vinyl tile or luxury vinyl plank with an appropriate MAPEI flooring adhesive; or glue-down wood flooring with any MAPEI urethane or hybrid-polymer-based wood adhesive.

*Mapesonic 2* reduces transmission of impact sound (such as footsteps and dropped objects) and airborne sound (such as voice and TV) through floors when installed under ceramic tile, stone, vinyl and wood floor coverings. It also helps to prevent existing or future in-plane floor cracks (with movement up to 3/8" [10 mm] wide) from transmitting through grout, ceramic tile and natural-stone assemblies.

### FEATURES AND BENEFITS

- Patented design: Sound-reduction performance with lighter weight and thickness
- Dual protection: Provides sound reduction and crack isolation
- Semi-rigid sheet: Easy to position on floor and cut to size
- Split-back release film: Installs faster than membranes with 1-piece liners
- White surface: Easy to view under lower-light conditions
- Thin-film adhesive backing: Bonds to a variety of substrates
- Time-saving: Prime, peel, stick and then install tile, vinyl or wood immediately
- No odor: Great for confined spaces
- Contains post-industrial recycled material

### INDUSTRY STANDARDS AND APPROVALS

- ASTM C627 (Robinson): See the "Product Performance Properties" section below for *Mapesonic 2*.
- ASTM E492-04 (Impact Sound), E90-04 (Airborne Sound), E2179 (Impact Sound): See the "Product Performance Properties" section below for *Mapesonic 2*.

- ANSI A118.13 (Bonded Sound Reduction Membranes for Thin-Set Ceramic Tile Installation): *Mapesonic 2* exceeds the standards for bonded sound-reduction membranes. See the "Product Performance Properties" section below for *Mapesonic 2*.
- ANSI A118.12 (Crack Isolation for Tile & Stone): *Mapesonic 2* exceeds the high-performance standards for crack isolation. See the "Product Performance Properties" section below for *Mapesonic 2*.

#### LEED v3 Points Contribution

#### LEED Points

MR Credit 4, Recycled Content\* ..... Up to 2 points

\* Using this product may help contribute to LEED certification of projects in the category shown above. Points are awarded based on contributions of all project materials.

### WHERE TO USE

Use under ceramic tile, natural stone, vinyl and wood flooring in interior, residential areas such as homes, apartments and condominiums. Also use in interior, light commercial areas such as office buildings.

#### Sound reduction (for tile, stone, vinyl and wood flooring)

- For interior residential and light commercial floors
- Ideal for multi-family or multi-story buildings where noise transmission is a common problem
- Reduces transmission of impact sound and airborne sound through floors covered with tile, stone, vinyl and wood floor coverings

#### Crack isolation (for grout, ceramic tile and natural stone)

- For interior residential and light commercial floors
- Helps to prevent existing or future in-plane substrate cracks (with movement up to 3/8" [10 mm] wide) from transmitting through grout, ceramic tile or natural stone

### LIMITATIONS

(for *Mapesonic 2* combined with *MAPEI SM Primer™* or *MAPEI SM Primer Fast*)

- Do not use over cracks or control joints subject to out-of-plane movement; or in-plane movement greater than 3/8" (10 mm).



- Do not cover expansion joints. Refer to most current TCNA Handbook, Detail EJ171; or TTMAC Tile Installation Manual, Detail 301MJ.
- Do not use over substrates containing asbestos, plank wood flooring, presswood, particleboard, chipboard, oriented strand board (OSB), pressure- or oil-treated plywood, Luan plywood, Masonite, self-stick tile, laminate, metal or fiberglass surfaces, or similar dimensionally unstable materials.
- Do not use where excessive substrate moisture and/or where negative hydrostatic pressure exists. The maximum allowable moisture vapor emission rate (MVER) in a concrete substrate for *Mapesonic 2* is 5 lbs. per 1,000 sq. ft. (2.27 kg per 92.9 m<sup>2</sup>) per 24 hours as determined by ASTM F1869 calcium chloride test. When moisture vapor emissions exceed 5 lbs. per 1,000 sq. ft. (2.27 kg per 92.9 m<sup>2</sup>) per 24 hours, contact MAPEI's Technical Services Department for recommendations.
- Do not use on vertical surfaces; under glass tile installations; as a waterproofing or roof deck membrane or wear surface; for submerged applications or floors subject to standing water; or on plywood in exterior applications.
- Do not use self-leveling products over *Mapesonic 2*.
- Do not use premixed products to set tile over *Mapesonic 2*.
- Do not install moisture-sensitive tile or stone with water-based setting materials.

Note: On occasion, dimensionally weak natural-stone tile that normally would not be categorized as moisture-sensitive (such as travertine, limestone, marble and agglomerates) can exhibit doming, cupping or curling when wet-set or medium-bed mortar methods of installation are used over impervious sheet membranes such as *Mapesonic 2*. Do not use medium-bed setting materials to compensate for irregularities in the substrate or to increase the elevation of the finished installation. A self-leveling underlayment or cured mortar bed should be applied to compensate for these conditions before installation of *Mapesonic 2*. When installing natural stone, always do a mockup area of the proposed installation and allow materials to reach full cure to ensure the desired effect. For more information regarding these methods or materials, contact MAPEI's Technical Services Department before installation or design.

## SUITABLE SUBSTRATES

- Fully cured concrete (at least 28 days old)
- Cement mortar beds and leveling coats
- Cement backer units (CBUs) – see manufacturer's installation guidelines
- Properly prepared cement terrazzo floors, and well-bonded ceramic tile and natural stone
- Well-bonded vinyl composition tile (VCT)
- APA Group 1 and CANPLY 0121 exterior-grade plywood (interior, residential and light commercial in dry conditions only)

Consult MAPEI's Technical Services Department for installation recommendations regarding substrates and conditions not listed.

### Tile Council of North America (TCNA) Statement on Deflection Criteria

Floor systems, including the framing system and subfloor panels, over which tile will be installed should be in conformance with the IRC [International Residential Code] for residential applications, the IBC [International Building Code] for commercial applications, or applicable building codes.

Note: The owner should communicate in writing to the project design professional and general contractor the

"intended use" of the tile installation, in order to enable the project design professional and general contractor to make necessary allowances for the expected live load, concentrated loads, impact loads, and dead loads including the weight of the tile and setting bed. The tile installer shall not be responsible for any floor framing or subfloor installation not compliant with applicable building codes, unless the tile installer or tile contractor designs and installs the floor framing or subfloor.

## SURFACE PREPARATION

- All suitable substrates must be smooth, structurally sound and free of any substance that could prevent adhesion.
- Unprimed gypsum-based patching or leveling compounds may leave a dusty residue on the surface. Clean the dusty substrate before priming with *MAPEI SM Primer* or *MAPEI SM Primer Fast*.
- Do not use chemical means (acid etching or stripping) to prepare approved substrates. Use mechanical methods only.
- To remove any bond-inhibiting materials, concrete substrates should be mechanically cleaned and prepared by diamond-cup grinding or other engineer-approved methods to obtain the International Concrete Repair Institute (ICRI) concrete surface profile (CSP) #2. If concrete requires more mechanical preparation, the increased profile of the surface should be made smooth by applying *Planipatch*® powder mixed with diluted *Planipatch Plus*™ liquid (1 part *Planipatch Plus* liquid per 3 parts water). For large areas, consider using one of MAPEI's self-leveling underlayments. See respective Technical Data Sheets (TDSs) for more information.
- Install *Mapesonic 2* only in conjunction with undiluted *MAPEI SM Primer* or *MAPEI SM Primer Fast*. Allow *MAPEI SM Primer* or *MAPEI SM Primer Fast* to dry tacky before *Mapesonic 2* is installed.

See MAPEI's "Surface Preparation Requirements" document in the Reference & Installation Guides section of the Tile & Stone Installation Systems page on MAPEI's Website.

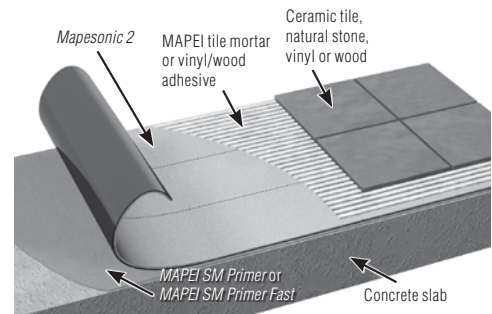

## PRODUCT APPLICATION

Read all installation instructions thoroughly before installation.

- Apply *Mapesonic 2* when substrate and ambient temperatures are between 40°F and 95°F (4°C and 35°C).
1. **Isolation of existing cracks before tile installation**
    - 1.1 *Mapesonic 2* may be applied directly to the substrate area that has existing in-plane cracks (with movement up to 3/8" [10 mm] wide).
    - 1.2 Cut *Mapesonic 2* to size so that the length and width of the membrane will cover the entire length and width of the crack, plus 3 times the width of the largest tile being used.
    - 1.3 Center the cut membrane over the crack's width and length. Mark on the floor where the membrane is to start.

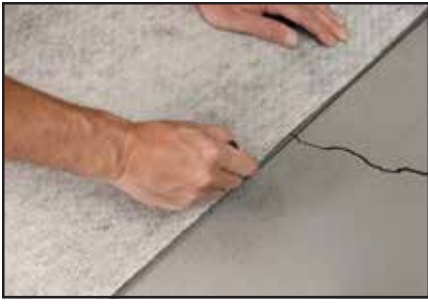

- 1.4 Set aside precut sections (or entire rolls) of *Mapesonic 2*. Continue with installation instructions at Step 2.3.

**2. Full-floor sound reduction (or crack isolation)**

- 2.1 To effectively achieve sound reduction and to isolate and protect an entire tile installation from existing or future substrate cracks, *Mapesonic 2* must be installed over 100% of the substrate that will be covered with ceramic tile or stone. For effective sound reduction, an approved acoustical sealant should fill gaps between the end of tile, vinyl or wood and the walls, columns, etc.
- 2.2 Unroll *Mapesonic 2* and cut it to size for the substrate to be tiled. For easier handling and installation, each roll may be cut into shorter lengths (such as 10 ft. [3,05 m]) before installation. Ensure that all edges or ends of each membrane section abut edges or ends of other sections. To ensure a flat surface and proper sound reduction, do not overlap edges or ends from one membrane section onto another.
- 2.3 Number each sheet and mark its starting point on the floor.
- 2.4 Set aside precut sections of *Mapesonic 2*.



- 2.5 With a roller or brush, prime floor with *MAPEI SM Primer* or *MAPEI SM Primer Fast*. The surface temperature of the prepared substrate must be at least 5 degrees F (2,8 degrees C) above the dew point to avoid condensation on the substrate surface as *MAPEI SM Primer* or *MAPEI SM Primer Fast* dries.
- 2.6 Let the primer dry until tacky (about 10 to 15 minutes).
- 2.7 Remove 6" (15 cm) of liner from the underside of the membrane.



- 2.8 Apply the membrane (at the previously marked starting point) to the tacky substrate.

- 2.9 Continue removing short lengths of liner and applying membrane to the tacky floor until the application area is covered.



- 2.10 For a proper bond between *Mapesonic 2* and the tacky floor, roll a 75- to 100-lb. (34,0- to 45,4-kg) roller over the installed membrane. For smaller pieces of membrane, use a wood float or steel trowel to apply pressure.



- 2.11 Cut out wrinkles or trapped objects in membrane with a razor knife, and replace with small pieces of membrane.



- 2.12 Layout lines for tile, vinyl or wood can be easily applied and viewed on the light-colored membrane.



**FLOORING INSTALLATION**

Tile and natural stone

1. Use an appropriate MAPEI latex polymer-modified mortar meeting ISO 13007 classification C2E and ANSI A118.4 and ANSI A118.11 industry standards to set tile. For moisture-sensitive tile or stone, use MAPEI's *Planicrete® W* urethane adhesive.

## Product Performance Properties (for *Mapesonic 2*)

Thickness (ASTM D5147)	76 mils nominal
Maximum crack movement capacity	3/8" (10 mm) wide, in-plane
Fabric color	White
VOCs (Rule #1168 of California's SCAQMD)	0 g per L
Shelf life	1 year when stored in a dry area in original shipping container at 73°F (23°C)

ANSI A118.12 (Crack-Isolation Membranes ..... 4.1 – Fungus and microorganism resistance:  
for Thin-Set Ceramic Tile and Dimension Stone Installation) 4.1.2 – 14-day incubation: Pass  
5.1.6 – After accelerated aging: Pass  
5.2 – Point load test:  
5.2.3 – Point load resistance after 28-day cure: Pass  
5.3 – Robinson floor test ASTM C627: Pass  
5.4 – System crack resistance test:  
5.4.9 – Standard performance: Exceeds  
5.4.9 – High performance: Exceeds

ANSI A118.13 (American National Standard ..... 4.1 – Fungus and microorganism resistance:  
Specification for Bonded Thin-Set Ceramic 4.1.2 – 14-day incubation: Pass  
Sound Reduction Membranes for Thin-Set 5.0 – Tests for system performance  
Ceramic Tile Installations) 5.1 – Shear strength to ceramic tiles and cement mortars  
5.1.3 – Seven-day shear strength: Pass  
5.1.4 – Seven-day water immersion shear strength: Pass  
5.1.5 – Four-week shear strength: Pass  
5.2 – Robinson floor test ASTM C627: Pass  
5.3 – Sound transmission reduction test  
5.3.8 – Testing according to Section 4 of ASTM E2179: Pass

<b>ASTM C627 Service Rating (Robinson)</b>	
<b>Residential and Light Commercial Applications</b>	
Measured rating	Light commercial
MAPEI grout	<i>Keracolor® S</i>
12" x 12" (30 x 30 cm) solid-body, unglazed porcelain with 1/4" (6 mm) expansion joints	Yes
MAPEI mortar	<i>Ultraflex™ 2</i>
<i>Mapesonic 2</i>	Yes
<i>MAPEI SM Primer</i> or <i>MAPEI SM Primer Fast</i>	Yes
6" (15 cm) concrete slab	Yes

ASTM Standards for Sound Reduction: MAPEI Corporation and MAPEI Inc. certify that the following sound tests (for tile) were conducted and results supplied by NGC Testing Services, Buffalo, NY. For sound-reduction ratings, higher numbers are preferred over lower numbers.

		<b>Sound-Reduction Ratings Over 6" (15 cm) Concrete Slab</b>			
		<b>Luxury Vinyl Tile<sup>1</sup></b>		<b>Solid Porcelain Tile<sup>2</sup></b>	
<b>ASTM test method</b>	<b>Type of sound-transmission measurement</b>	<b>Suspended ceiling<sup>3</sup></b>	<b>No suspended ceiling<sup>4</sup></b>	<b>Suspended ceiling<sup>3</sup></b>	<b>No suspended ceiling<sup>4</sup></b>
E492-09 / E989-06 (IIC)	Impact sound	70	50	70	50
E2179-03 (Delta IIC)	Impact sound	–	20	–	21
E90-04 / E413-10 (STC)	Airborne sound	67	52	66	52

<sup>1</sup> 6" x 48" (15 x 122 cm) luxury vinyl tile flooring installed with Ultrabond ECO 360 (with a 1/16" x 1/32" x 1/32" [1,5 x 1 x 1 mm] U-notched trowel)

<sup>2</sup> 12" x 12" (30 x 30 cm) solid-body, unglazed porcelain tile installed with Ultraflex 2 mortar (with a 1/4" x 3/8" [6 x 10 mm] square-notched trowel) and Keracolor S grout

<sup>3</sup> Drywall grid suspension system consisting of 5/8" (16 mm) Type X gypsum board (2.3 lbs. per sq. ft. [11,2 kg per m<sup>2</sup>]) attached with screws 12" [30 cm] on center to suspended grip suspension system; and 12" [30 cm] plenum with 3-1/2" (8,9 cm) lay-in fiberglass insulation (0.16 lbs. per sq. ft. [0,78 kg per m<sup>2</sup>])

<sup>4</sup> Bare concrete ceiling in room below

		Sound-Reduction Ratings Over 8" (20 cm) Concrete Slab	
		Luxury Vinyl Tile <sup>5</sup>	Solid Porcelain Tile <sup>6</sup>
ASTM test method	Type of sound-transmission measurement	Suspended ceiling <sup>7</sup>	Suspended ceiling <sup>7</sup>
E492-09 / E989-06 (IIC)	Impact sound	72	72
E90-04 / E413-10 (STC)	Airborne sound	66	66

<sup>5</sup> 6" x 48" (15 x 122 cm) luxury vinyl tile flooring installed with Ultrabond ECO 360 (with a 1/16" x 1/32" x 1/32" [1,5 x 1 x 1 mm] U-notched trowel)

<sup>6</sup> 12" x 12" (30 x 30 cm) solid-body, unglazed porcelain tile installed with Ultraflex 2 mortar (with a 1/4" x 3/8" [6 x 10 mm] square-notched trowel) and Keracolor S grout

<sup>7</sup> Drywall grid suspension system consisting of 5/8" (16 mm) Type X gypsum board (2.3 lbs. per sq. ft. [11,2 kg per m<sup>2</sup>]) attached with screws 12" [30 cm] on center to suspended grip suspension system; and 12" [30 cm] plenum with 3-1/2" (8,9 cm) lay-in fiberglass insulation (0.16 lbs. per sq. ft. [0,78 kg per m<sup>2</sup>])

## Product Performance Properties (for MAPEI SM Primer or MAPEI SM Primer Fast)

Color (when dry)	Clear
Drying time before installation of ceramic tile or stone	10 to 15 minutes (depending on temperature, humidity and substrate porosity)
Shelf life	1 year when stored in original, unopened container at between 40°F and 95°F (4°C and 35°C)

## Packaging and Approximate Coverage\*

Product	Size	Coverage
MAPEI SM Primer Fast	Jug: 1 U.S. gal. (3,79 L)	300 to 350 sq. ft. (27,9 to 32,5 m <sup>2</sup> )
MAPEI SM Primer	Jug: 1 U.S. gal. (3,79 L)	300 to 350 sq. ft. (27,9 to 32,5 m <sup>2</sup> )
MAPEI SM Primer	Pail: 5 U.S. gals. (18,9 L)	1,500 to 1,750 sq. ft. (139 to 163 m <sup>2</sup> )
Mapesonic 2	Boxed roll: 39" x 49.2' (99 cm x 15 m)	160 sq. ft. (14,9 m <sup>2</sup> )

\* Coverage shown is for estimating purposes only. Actual jobsite coverage depends on substrate conditions as well as the type of roller or brush used.

Continued from Page 3

Note: For installation of tile larger than 18" x 18" (46 x 46 cm), longer mortar-cure times may be required before tile can be grouted or walked on. For shorter turnaround times when installing larger tile, use the MAPEI rapid-set mortar *Ultraflex™ LFT™ Rapid*, *Ultracontact™ RS* or *Granirapid®*.

### Glue-down wood flooring

- Follow Steps 2.1 through 2.12 above.
- Apply a MAPEI urethane or hybrid-polymer-based wood adhesive (*Ultrabond ECO® 975*, *Ultrabond ECO 980* or *Ultrabond ECO 985*). Follow wood-flooring manufacturer's instructions and recommended trowel size.

### Luxury vinyl tile/plank

- Apply MAPEI's *Ultrabond ECO 360* adhesive.
- Follow the luxury vinyl tile/plank manufacturer's instructions and trowel-size recommendations.

## EXPANSION JOINTS

- Do not cover any substrate movement joints with *Mapesonic 2*, mortar or tiles. Provide for movement joints where specified. Refer to the most current TCA handbook for

ceramic tile installation, Detail EJ171-07, or TTMAC Tile Installation Manual, Detail 301MJ.

- When necessary, cut tiles along both edges of the expansion joints. Do not allow tile and mortar to overlap the joints.
- Protect tilework with metal strips (edge metal) along both edges of structural building expansion joints.
- Install the specified compressible bead and sealant into all expansion and control joints.

## GROUTING

Select an appropriate MAPEI cement grout meeting ISO 13007 classification CG2WA or CG2WAF and ANSI A118.6 or ANSI A118.7 industry standards, or an epoxy grout meeting ISO 13007 classification R2/RG or RG, as well as ANSI A118.3 industry standards. For additional information, instructions and protection recommendations, see the respective TDS for the MAPEI grout selected.

## CLEANUP

Remove excess *MAPEI SM Primer* or *MAPEI SM Primer Fast* with mineral spirits.

# Mapesonic 2™



## PROTECTION

- Provide for dry storage on site at between 40°F and 95°F (4°C and 35°C). Deliver materials at least 24 hours before application.
- Do not store *Mapesonic 2*, *MAPEI SM Primer* or *MAPEI SM Primer Fast* in direct sunlight.
- Protect installation from contamination and damage before and during tilework.
- Do not allow *MAPEI SM Primer* or *MAPEI SM Primer Fast* to freeze.
- Always provide proper protection of finished floors when heavy equipment (such as fork lifts or scissor lifts) is to be used over installations with sheet membrane underlayments during construction.

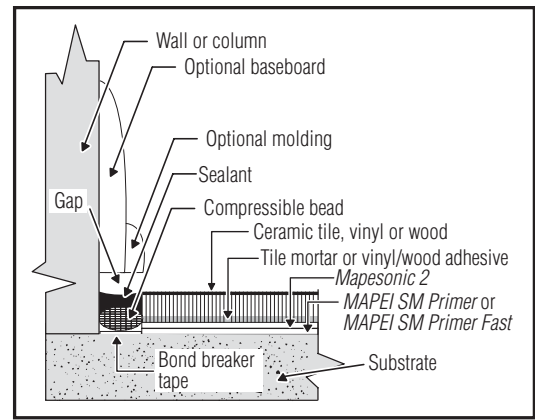

## RELATED DOCUMENTS

Reference Guide: Surface Preparation Requirements for tile and stone installation systems

RGTO309\*

\* At [www.mapei.com](http://www.mapei.com)

Refer to the SDS for specific data related to health and safety as well as product handling.

## STATEMENT OF RESPONSIBILITY

Before using, user shall determine the suitability of the product for its intended use and user alone assumes all risks and liability whatsoever in connection therewith.

**ANY CLAIM SHALL BE DEEMED WAIVED UNLESS MADE IN WRITING TO US WITHIN FIFTEEN (15) DAYS FROM DATE IT WAS, OR REASONABLY SHOULD HAVE BEEN, DISCOVERED.**

We proudly support the following industry organizations:



### MAPEI Headquarters of the Americas

1144 East Newport Center Drive  
Deerfield Beach, Florida 33442  
1-888-US-MAPEI (1-888-876-2734) /  
(954) 246-8888

### Technical Services

1-800-992-6273 (U.S. and Puerto Rico)  
1-800-361-9309 (Canada)

### Customer Service

1-800-42-MAPEI (1-800-426-2734)

### Services in Mexico

0-1-800-MX-MAPEI (0-1-800-696-2734)

**Edition Date:** February 25, 2016

PR: 6565 MKT: 16-1068

For the most current **BEST-BACKED™** product data and warranty information, visit [www.mapei.com](http://www.mapei.com).

All Rights Reserved. Printed in the USA. © 2016 MAPEI Corporation.