



## Stair Installation Guide

# Installation Instructions Option 1

---

- 1** Remove existing floor covering from existing tread and riser including all nails and staples. Ensure that the surface is clean and level.
- 2** Attach shims to the existing riser for the remodel riser to attach to later.
- 3** Starting at the bottom of the stairs measure for new riser with Tread Tool (sold separately), and transfer that mark to new riser and then cut for length. Also cut the new riser to the correct height which when cut will be flush with the top of the existing tread.
- 4** Glue new riser in place with ¼” bead of urethane adhesive. A small brad or pin nail can be placed at both ends of riser to hold in place while adhesive cures if desired.
- 5** Measure existing tread for length with Tread Tool (sold separately), and then transfer that mark to retread for length to be cut. Cut new retread to correct length. Cut depth of retread to fit existing stair tread.
- 6** After cut is complete apply adhesive to underside of retread using ¼” bead of **URETHANE ADHESIVE.**
- 7** A small brad or pin nail can be placed at left rear and right rear of new retread to hold in place while adhesive cures. Remove all wet adhesive from finished surface before adhesive cures following urethane adhesive manufacturer’s instructions.
- 8** Repeat this process for each riser and retread working from bottom to top of stairs installing riser, retread, riser, retread etc. until your new beautiful stairs are complete.

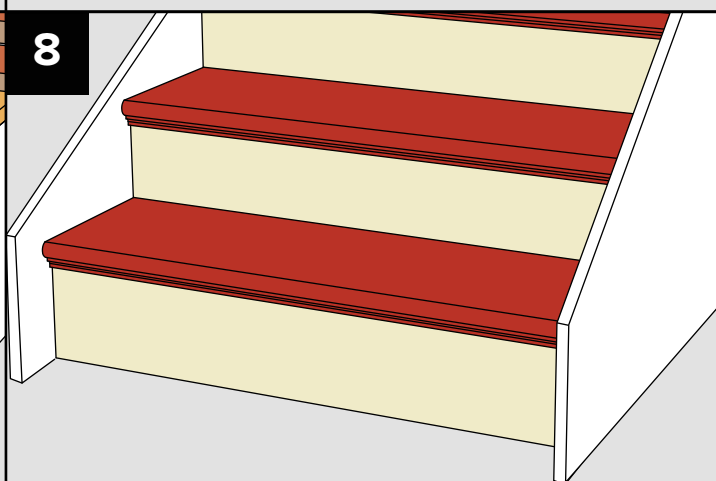
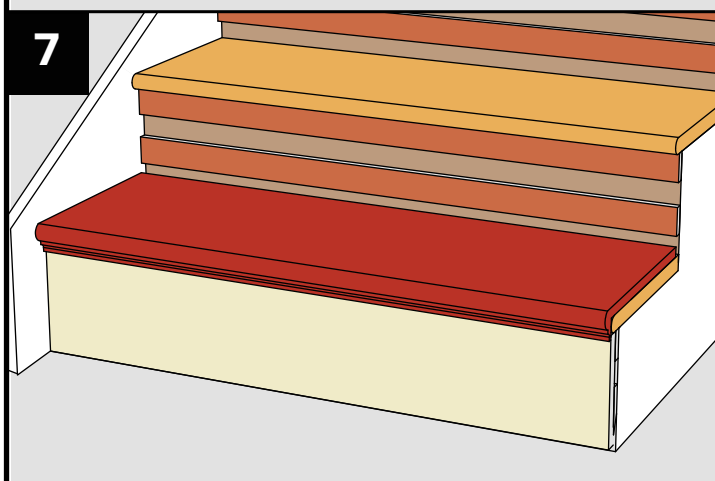
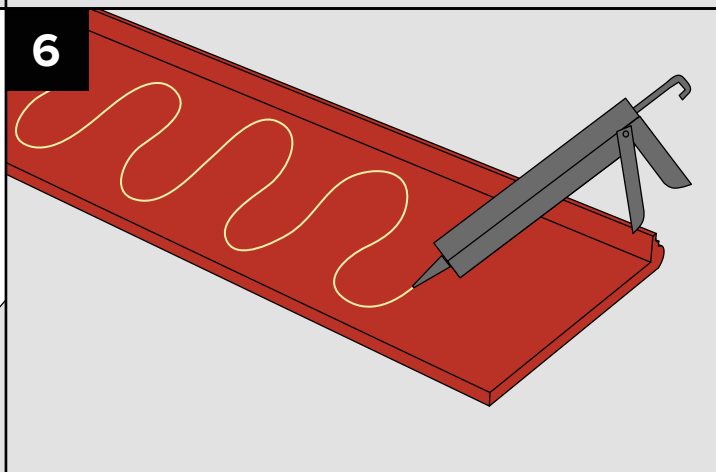
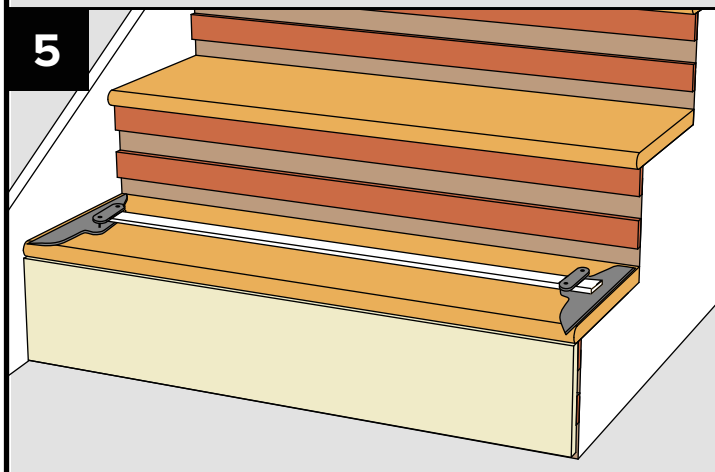
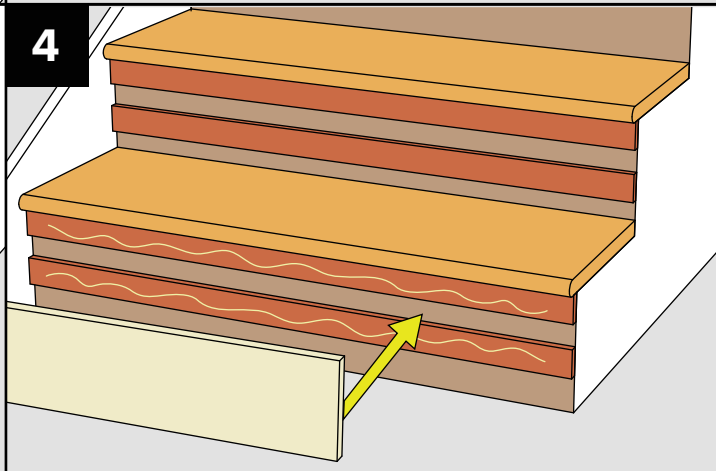
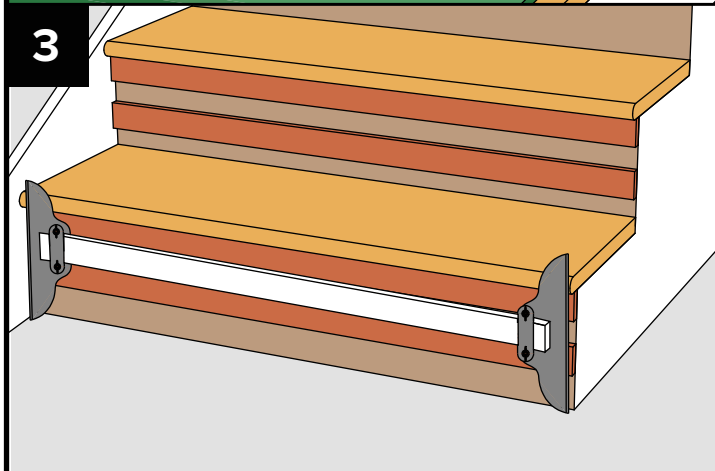
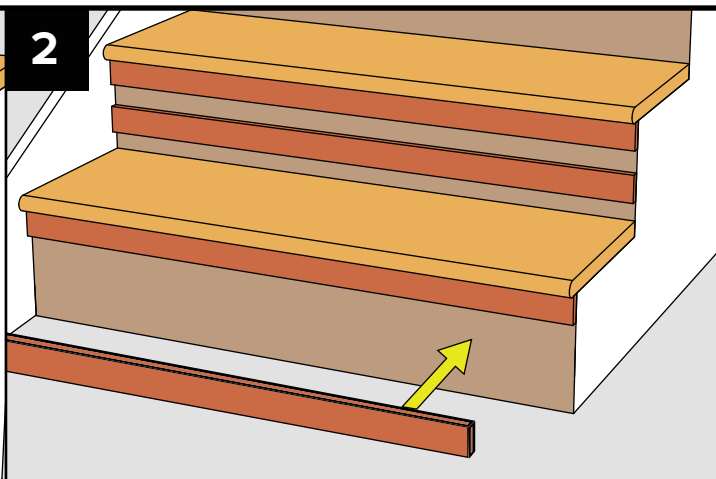
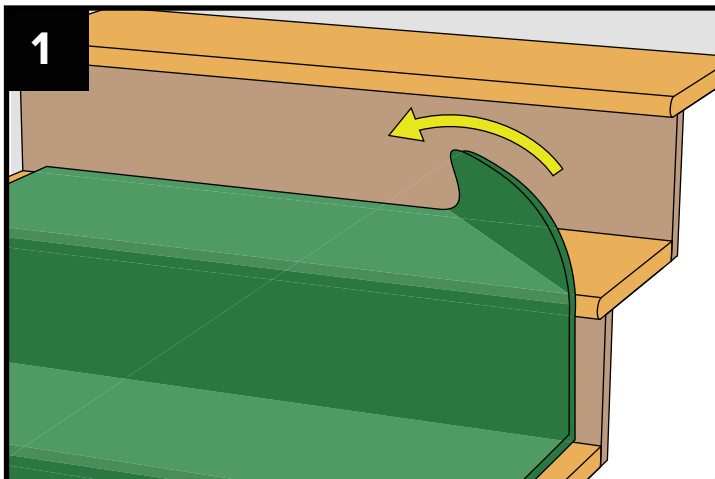

# Installation Instructions Option 2

---

- 1** Remove existing floor covering from existing tread & riser including all nails and staples down to a clean, level, dust free surface.
- 2** Cut off existing nosing flush with existing riser.
- 3** Starting at the bottom of the stairs measure for new riser with Tread Tool (sold separately), and transfer that mark to new riser and then cut for length. Also cut the new riser to the correct height which when cut will be flush with the top of the existing tread.
- 4** Glue new riser in place with ¼” bead of urethane adhesive. A small brad or pin nail can be placed at both ends of riser to hold in place while adhesive cures if desired.
- 5** Measure existing tread for length with Tread Tool (sold separately), and then transfer that mark to retread for length to be cut. Cut new retread to correct length. Cut depth of retread to fit existing stair tread.
- 6** After cut is complete apply adhesive to underside of retread using ¼” bead of **URETHANE ADHESIVE.**
- 7** A small brad or pin nail can be placed at left rear and right rear of new retread to hold in place while adhesive cures. Remove all wet adhesive from finished surface before adhesive cures following urethane adhesive manufacturer’s instructions.
- 8** Repeat this process for each riser and retread working from bottom to top of stairs installing riser, retread, riser, retread etc. until your new beautiful stairs are complete.

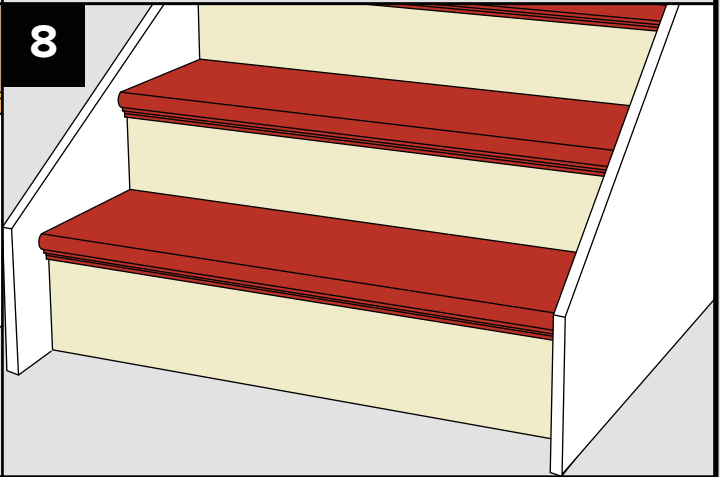
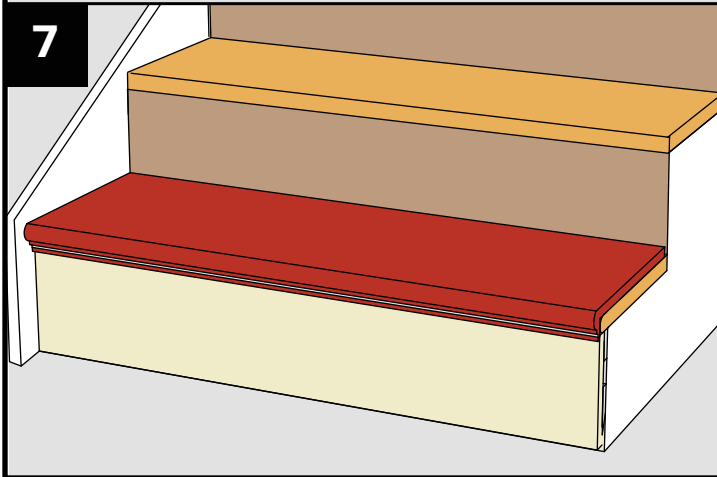
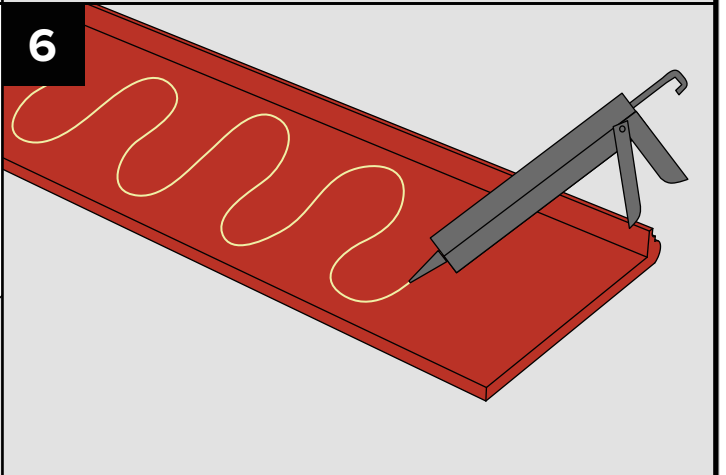
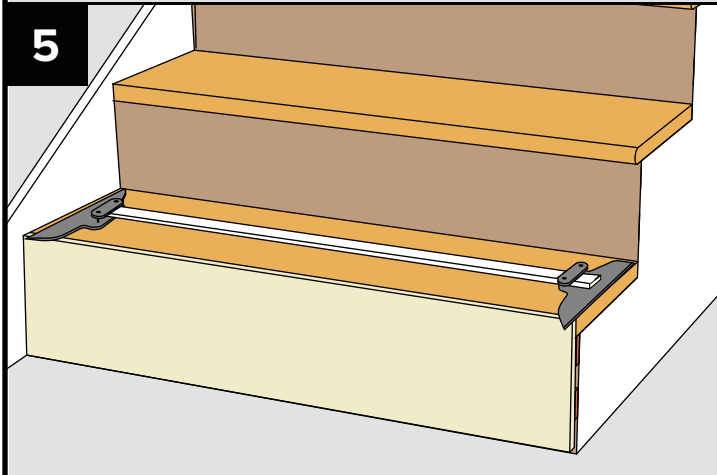
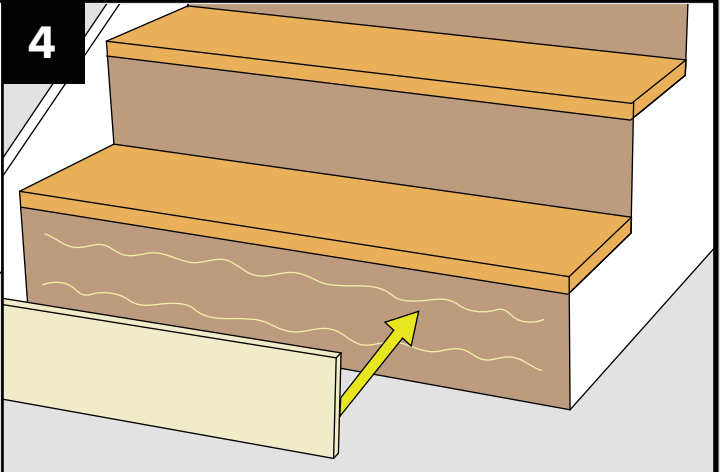
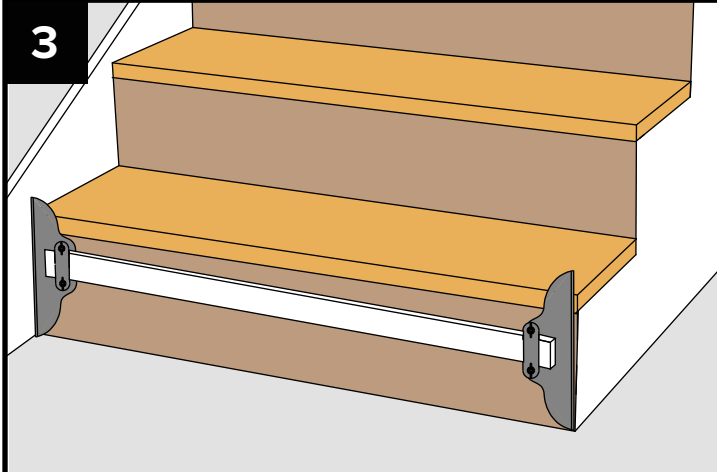
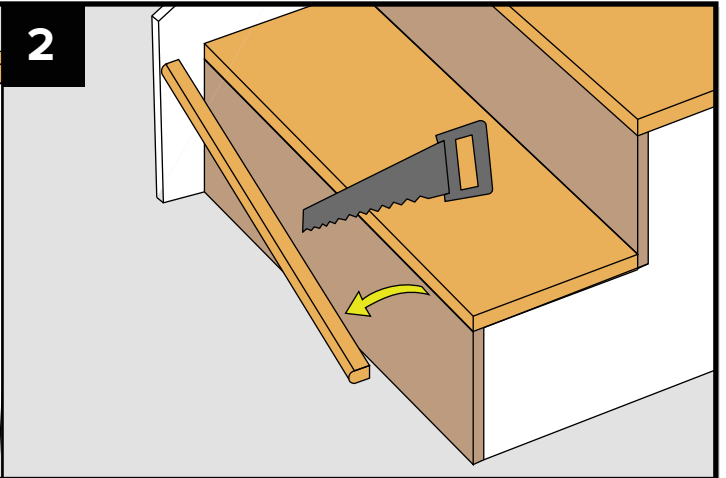
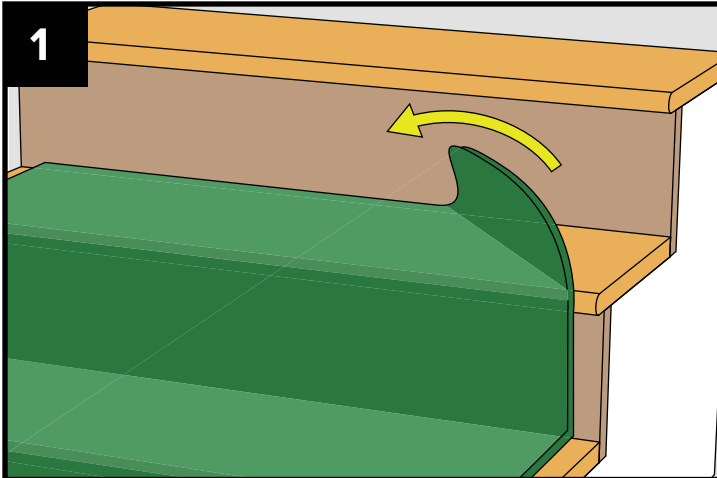

# STAIR BUILDING CODE

A nosing not less than 3/4 inch but not more than 1-1/4 inches shall be provided on stairways with solid risers (See Fig. 1). The greatest nosing projection shall not exceed the smallest nosing projection by more than 3/8 inch between two stories, including the nosing at the level of floors and landings (See Fig. 3). The maximum riser height shall be 7-3/4 inches. The riser shall be measured vertically between leading edges of the adjacent treads (See Fig. 2). The greatest riser height within any flight of stairs shall not exceed the smallest be more than 3/8 inch (See Fig. 4). The minimum tread depth shall be 10 inches. The tread depth shall be measured horizontally between the vertical planes of the foremost projection of adjacent tread's leading edge. The greatest tread depth within any flight of stairs shall not exceed the smallest by more than 3/8 inch (See Fig. 5).

